



ECE6615: Sensor Networks Spring 2015

Homework 1 for Distance Learning Students

Given: January 19, 2015

Due: March 13, 2015 (MIDNIGHT 11:59pm)

Submission Instructions:

1. Please put “[ECE6615] HOMEWORK 1 - DL” in the subject line.
2. Submit your homework as on-line files (such as a DOC or a PDF file) to infocom@ece.gatech.edu.

Dr. Ian F. Akyildiz

Ken Byers Chair Professor in Telecommunications

Broadband Wireless Networking Laboratory

School of Electrical and Computer Engineering

Georgia Institute of Technology, Atlanta, GA 30332

Tel.: 404-894-5141; Fax: 404-894-7883; E-Mail: infocom@ece.gatech.edu

QUESTION 1 (ENERGY MODELING & RELIABILITY)

For this question, consider the energy consumption models for sensing, computation, and communication.

You will also need to use the **RF230 Transceiver datasheet**:

http://www.atmel.com/dyn/resources/prod_documents/doc5131.pdf

Assume a network where each sensor should wake up once a second, measure a value, perform calculations and transmit it over the network. Consider the following:

- Assume sensing energy is negligible
- Calculations needed: 5K instructions (for measurement and preparation for sending)
- Time to send information: 50 bytes for sensor data, (another 250 byte for forwarding external data)
- Energy needed to sleep for the rest of the time (sleep mode)

Assume IRIS mote (Atmel processor + RF230 transceiver) with the following:

- Computation power (P_p) is 24mW for IRIS
- 1 instruction takes an average of 3 cycles, where Atmel processor operates at 8MHz
- For start-up, assume $P_{LO} = 4.5\text{mW}$, $t_{st} = 1.065\text{ms}$
- For switch, assume $P_{LO} = 23.4\text{mW}$, $t_{sw} = 25\text{us}$
- For receive energy, $P_{LO} + P_{RX} = 46.5\text{mW}$
- For transmit energy, $P_{LO} + P_{TX} = 49.5\text{mW}$

- For sleep energy, $P_{SL} = 24 \text{ uW}$
 - Assume transmission rate as 250kbps
 - The sensor is supplied with 2 x 1.5V AA batteries, each of which has energy of 1150mAh
- a) Find the total energy consumption of a mote in one second.
 - b) Assuming the batteries loose 15% energy/year, calculate the lifetime of a mote.
 - c) Start-up and switching is much more complicated than that can be modeled by a single parameter P_{LO} . Refer to Figure 7-1, Table 7-1, and Table 11-8 in the RF230 Transceiver datasheet and discuss the effects of the start-up and switching mechanism on the overall lifetime. What is the consumed power and time for (i) start-up for transmit, (ii) start-up for receive, (iii) switching from receive to transmit and (iv) switching from transmit to receive?

QUESTION 2. (Query Processing)

Consider a sensor network composed of 150 sensor devices deployed in the ground floor of the Georgia Tech Campus Recreation Center. There are temperature sensor devices uniformly distributed in the main fitness room, in the two swimming pools, and in the five locker rooms. You want to constitute a temperature map of the floor at various resolutions in order to adapt the AC/Heating system parameter values, the minimum resolution being the average temperature of the entire floor and the maximum resolution being the temperature of each sensor. You should also be able to adjust the temperature by areas independently, e.g., the main fitness room and the swimming pools average temperatures should be different. The required resolution for the temperature map can change over time. Consider that sensor nodes are battery powered and that lifetime is a crucial property for this sensor network.

Describe a solution to this task. In particular, you should:

- Propose an adaptive aggregation scheme that accounts for the required resolution of the temperature map. You can assume that the network topology is fixed, but you want to distribute the energy consumption uniformly among all the nodes.
- Propose a communication protocol aimed at dynamically exploiting the spatial-temporal correlation of the measurements.
- Specify a SQL-like query message that would efficiently provide support to this specific application.

Briefly discuss pros and cons for your design choices and clearly state all the working assumptions made.

- Consider a TAG scheme with the query:

```
SELECT AVE (temperature), humidity/10%, FROM sensors, Group BY humidity/10%
```

According to the topology in the following figure, what is the information table that can be generated at A?

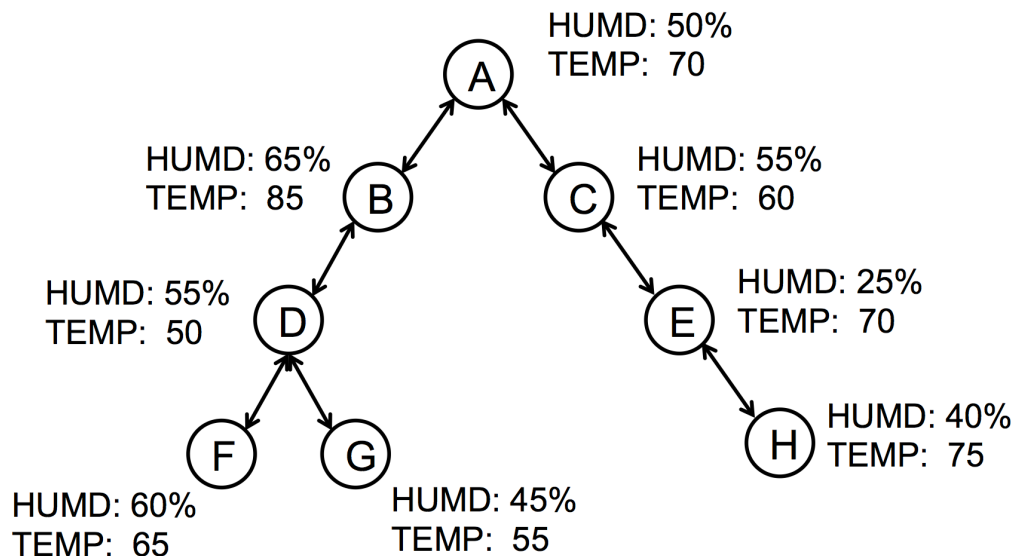

QUESTION 3. (Physical Layer)

Consider a chain topology of 5 nodes where inter-node distance is 15m. End-to-end packet error rate of 10^{-2} is required for an application.

Consult the datasheets when necessary and state any references to the datasheet and assumptions you make.

- a) Assuming independent and identical errors at each hop, what is the required packet error rate for each hop?
- b) For a packet size of 50bytes, and independent and identical bit errors, what is the required bit error rate at each hop?
- c) For a Mica2 mote that uses 2-FSK modulation, what is the required SNR in dB at the data rate of 250kbps?
- d) Consider a log-normal fading channel model without fading ($X=0$). At the highest data rate and transmit power of 0dBm, what is the maximum path loss exponent that can be accommodated to guarantee the error requirement?

QUESTION 4. (S-MAC)

Consider the grid topology in the Figure.

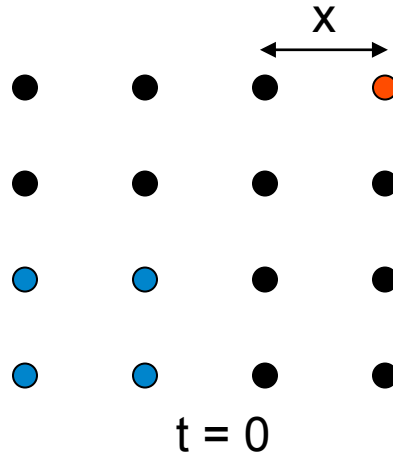

The blue nodes are the source nodes that need to send a packet to the sink (red node). Assume that all immediate horizontal and vertical neighbors of a node are accessible ($\sqrt{2} \cdot x > R > x$). The total time for transmitting a packet is 3 sec.

Assume S-MAC with adaptive listening is the MAC protocol at each node. All the nodes are awake for 1 sec. and asleep for 4 sec. For example, all the nodes are awake from $t=0$ to $t=1$, go to sleep until $t=5$, and repeat.

- a) Calculate the time at which the sink receives all the packets from all the blue nodes. (You can assume any route respecting the transmission range of nodes)
- b) Show the state of the network in each time slot.

State clearly any assumption you make.

Hints for (a) and (b):

- 1- Assume perfect carrier sensing. When a particular node transmits during time $[t_0, t_0+3]$, no other node in its neighborhood can transmit simultaneously.
- 2- Assume RTS/CTS exchanges are instantaneous and if a node starts transmitting, it will continue until the packet is transmitted